

ASSEMBLY INFORMATION

for the

The logo for 'elite', with the word 'elite' in white lowercase letters on a green square background.

Larder Unit

Soft Close 1693 - 1993mm

Contents:

- Parts Required for the Slide Cover Assembly 2
- Assembly of the Slide Cover to the Frame 3 - 5
- Parts Required for the Frame and Baskets 6
- Assembly of the Frame and Baskets 7
- Overview and Parts Required for attach Brackets 8
- Assembly of the Brackets to the Frame 9 - 11

Parts Required for the Assembly of the Slide Cover to the Frame

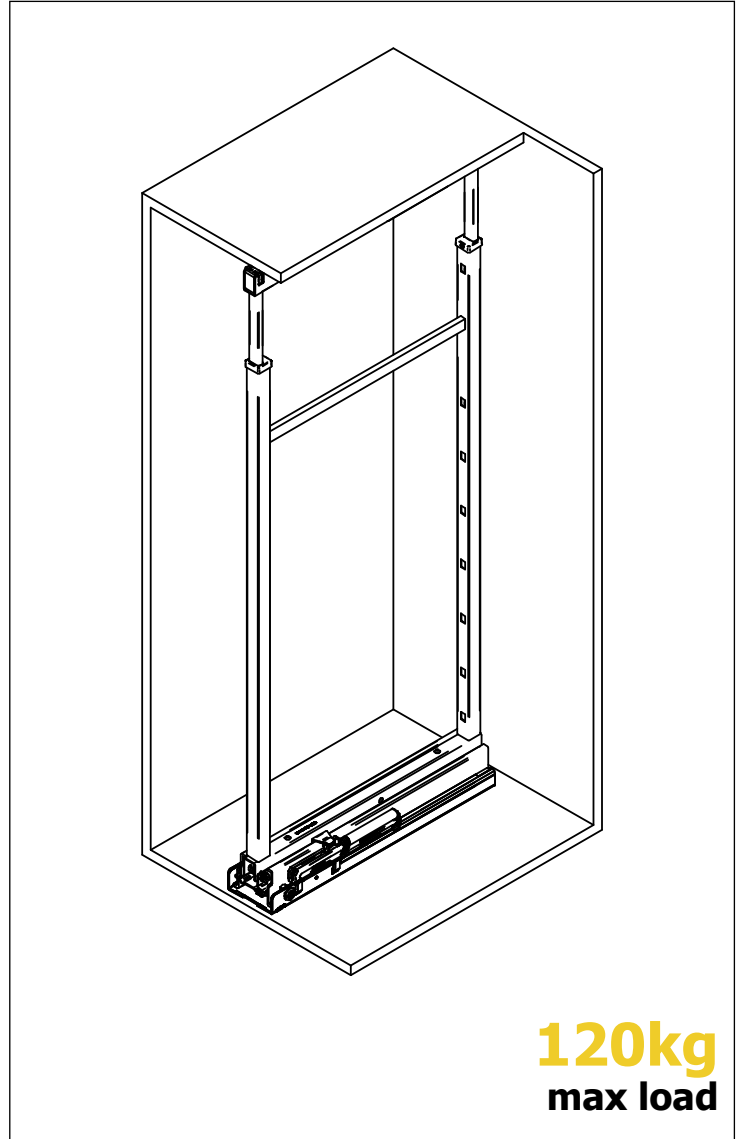
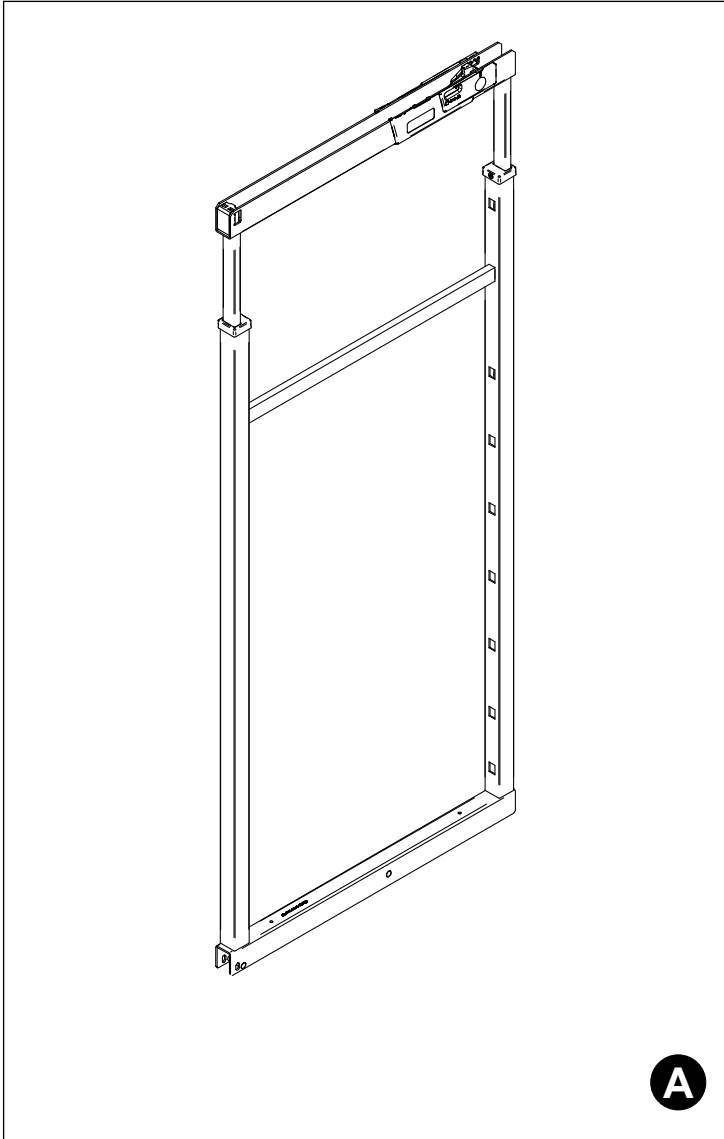

120kg
max load

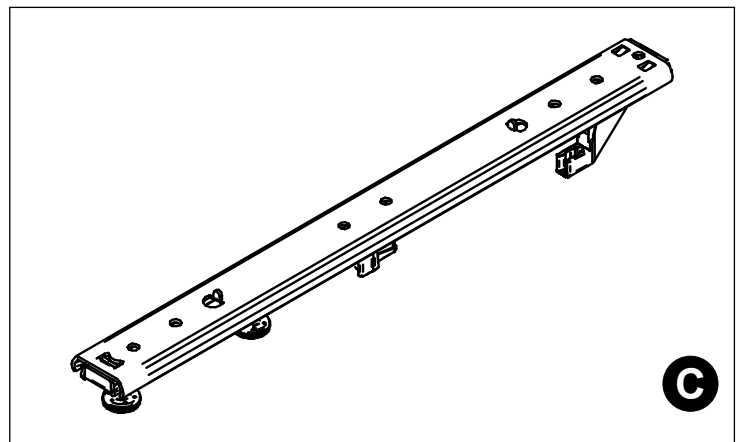
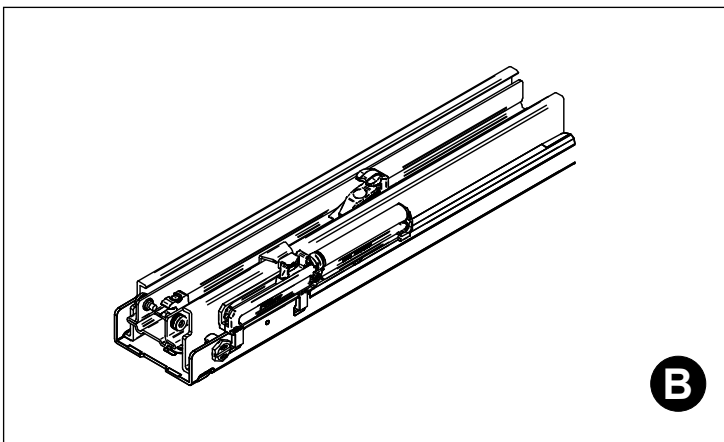

ATTENTION

The Larder Unit must be fixed to the wall as illustrated here.

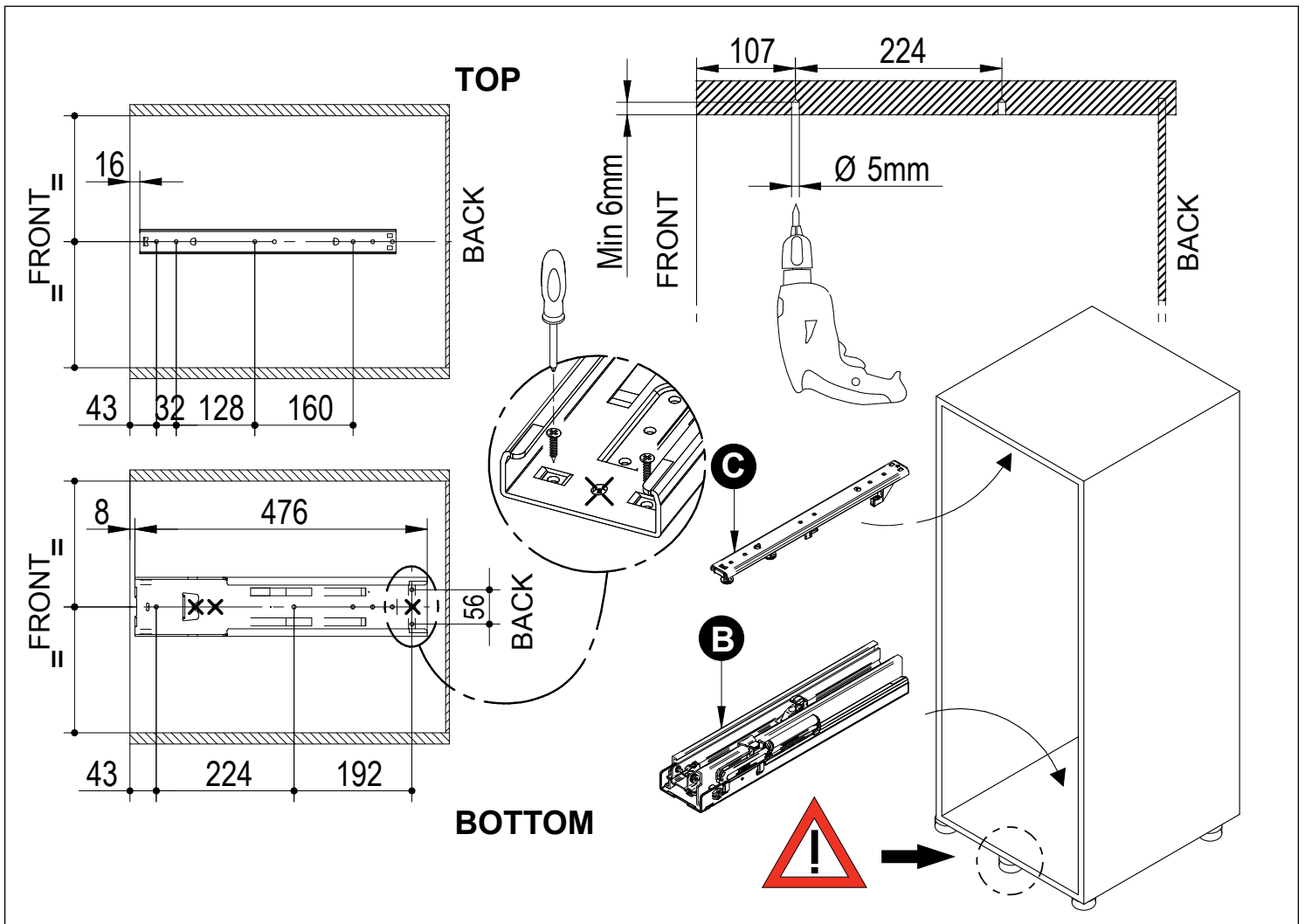
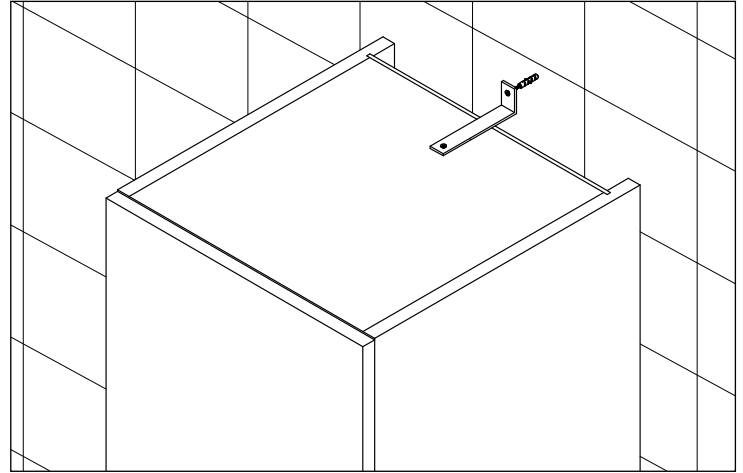

Make sure when mounting that the runner is protected from dust and foreign bodies resulting from processing / installation. There is no need to oil this runner.

Assembly of the Slide Cover to the Frame

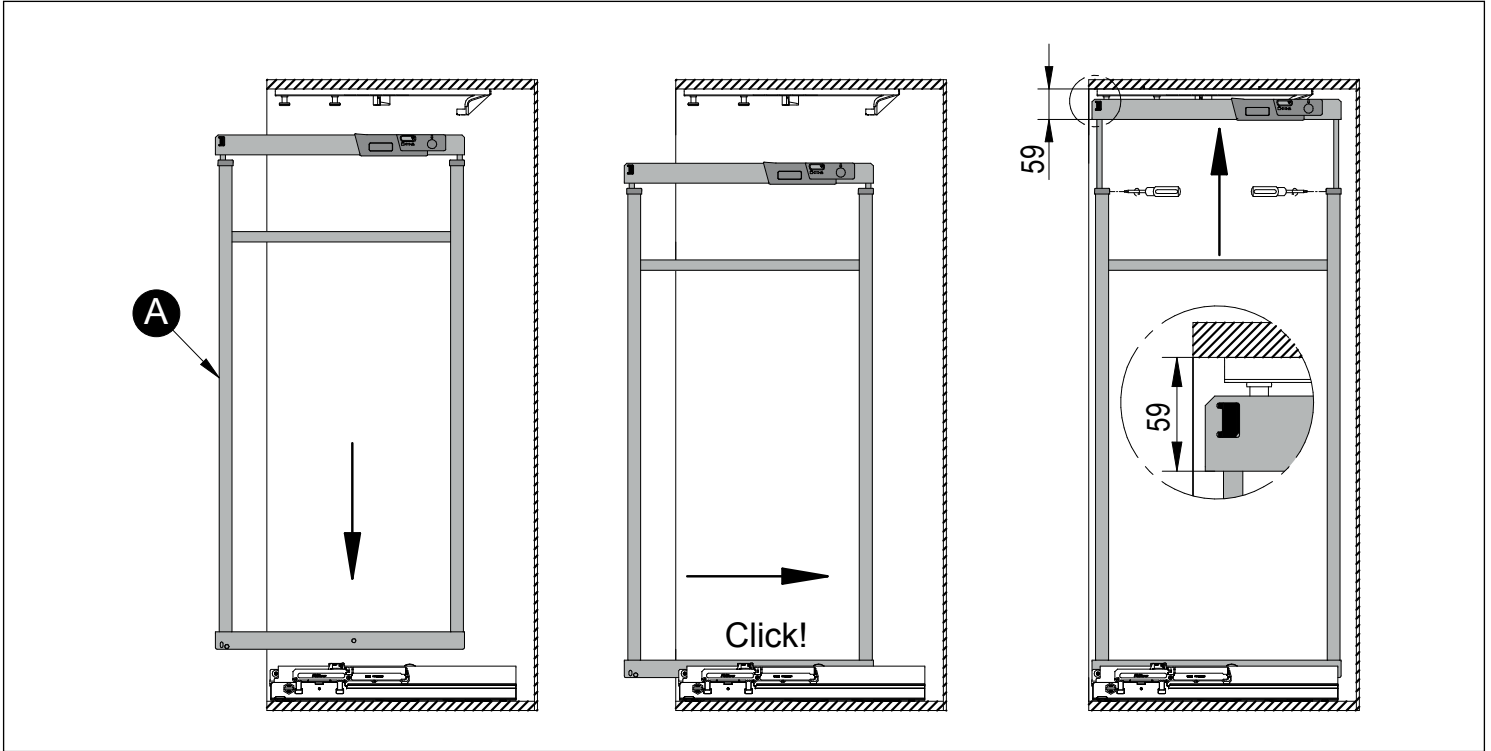

FOR ADJUSTMENT

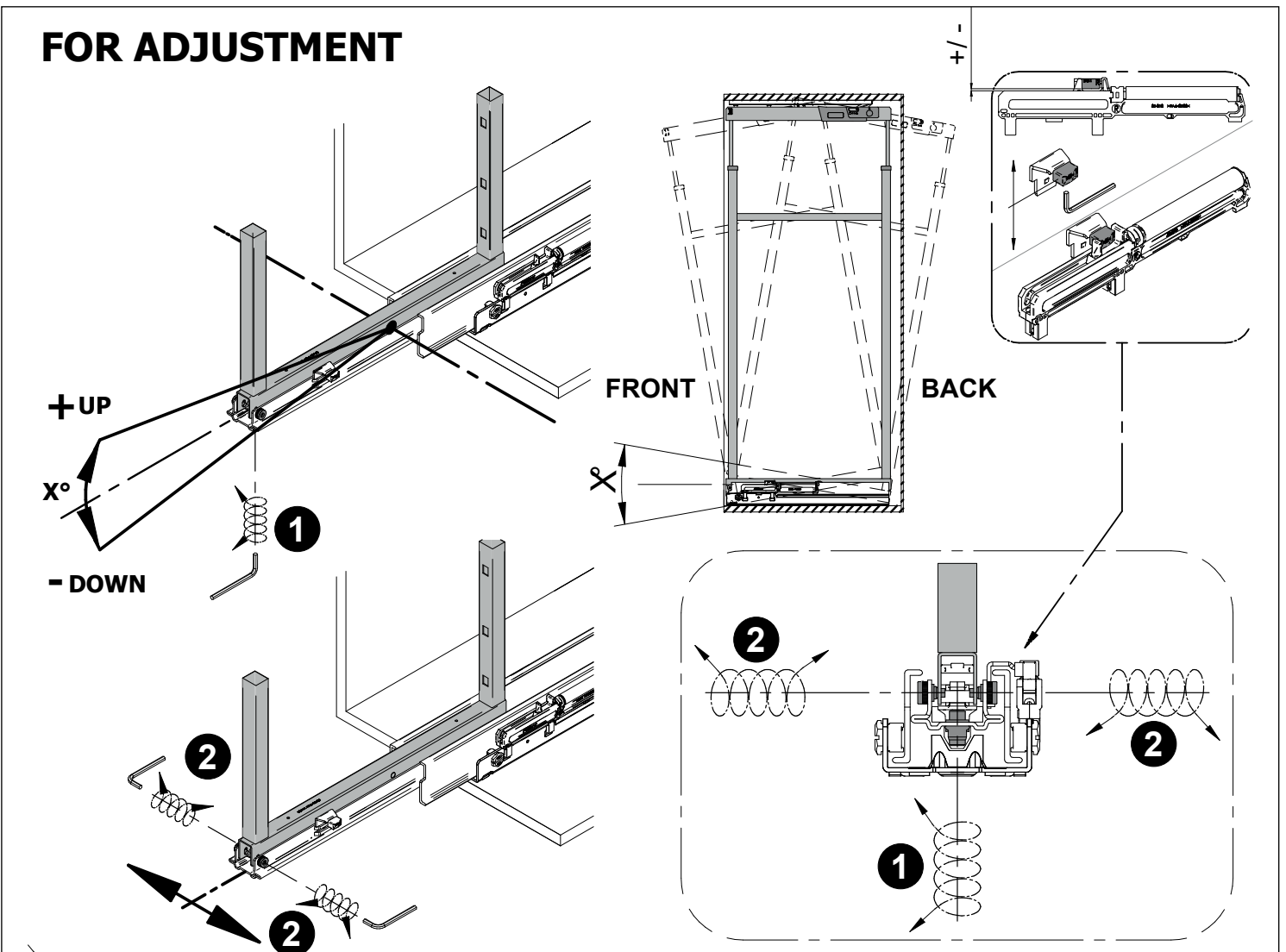

Assembly of the Slide Cover to the Frame

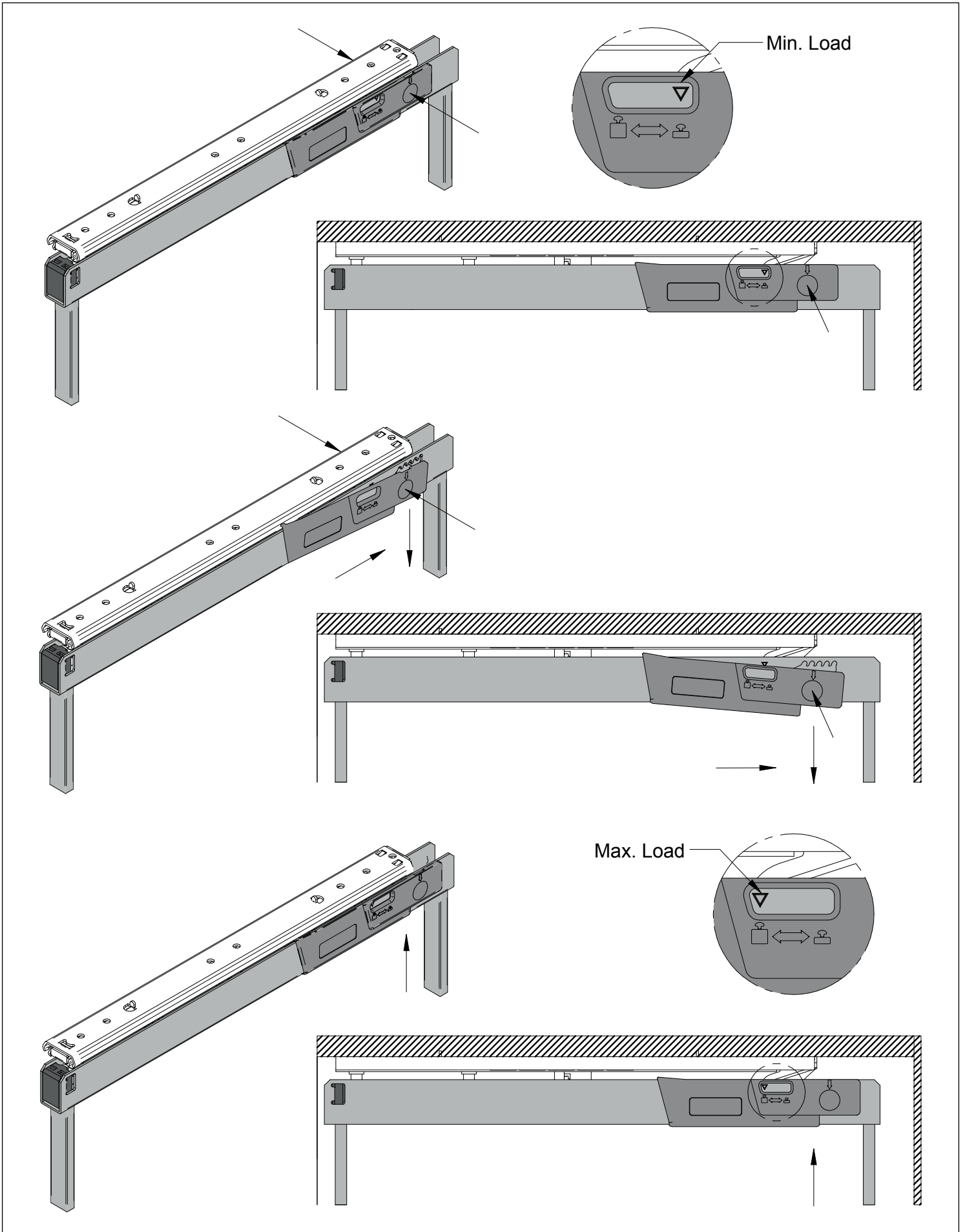

Parts Required for the Frame and Baskets

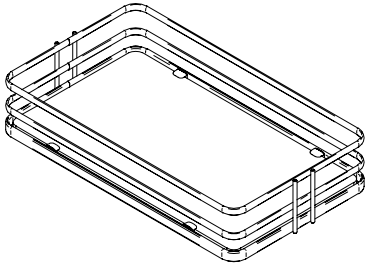

2.5kg
300mm

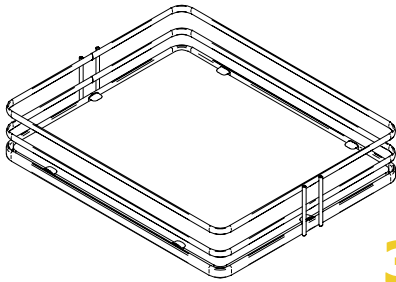

3.8kg
400mm

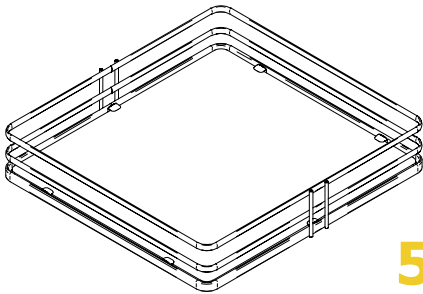

5.6kg
600mm

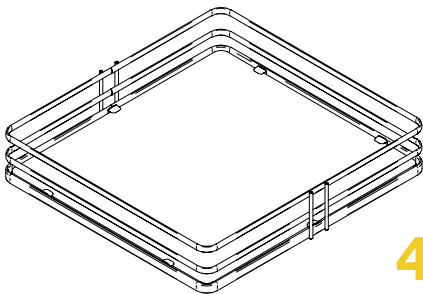

4.6kg
500mm

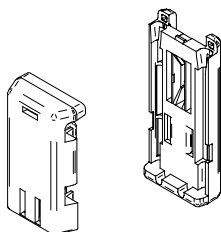

Assembly of the Frame and Baskets to the Cabinets

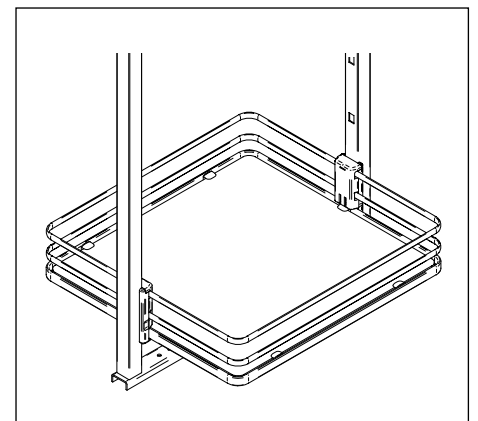
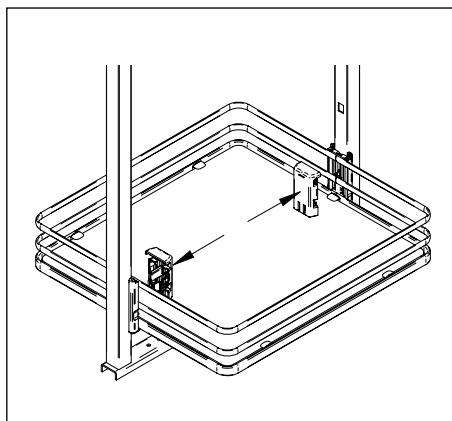
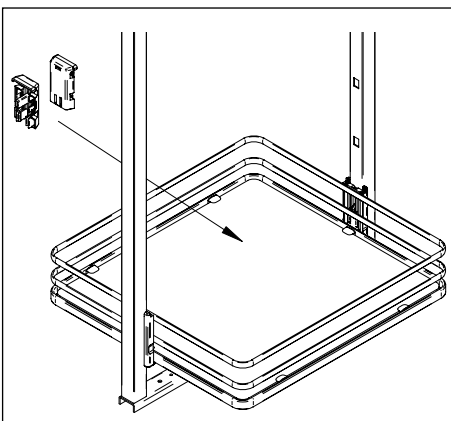
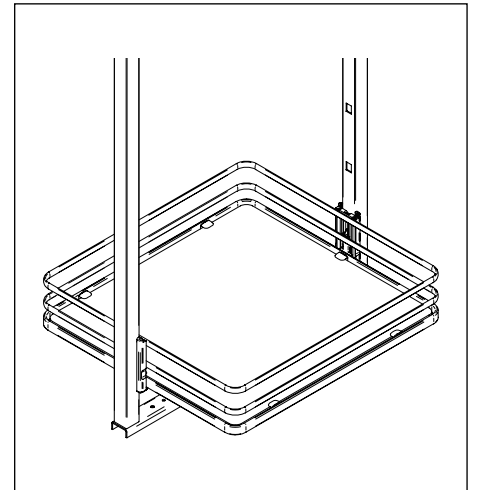
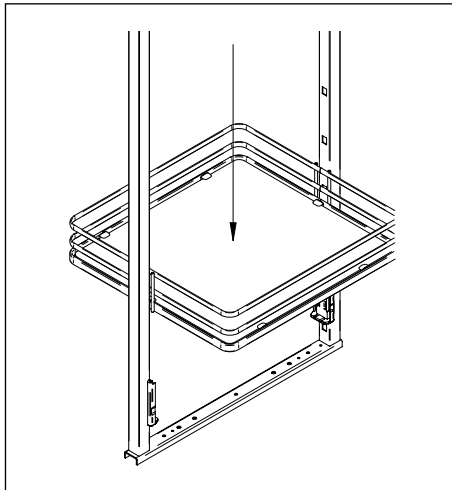
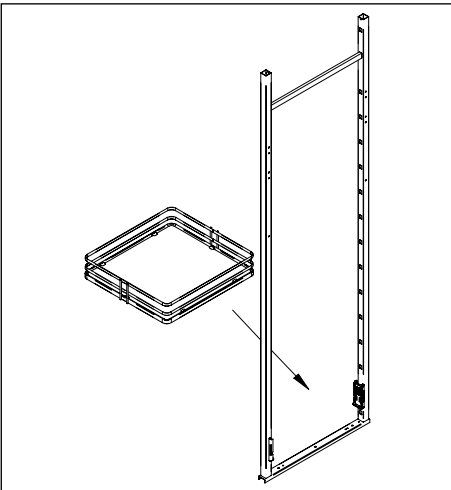
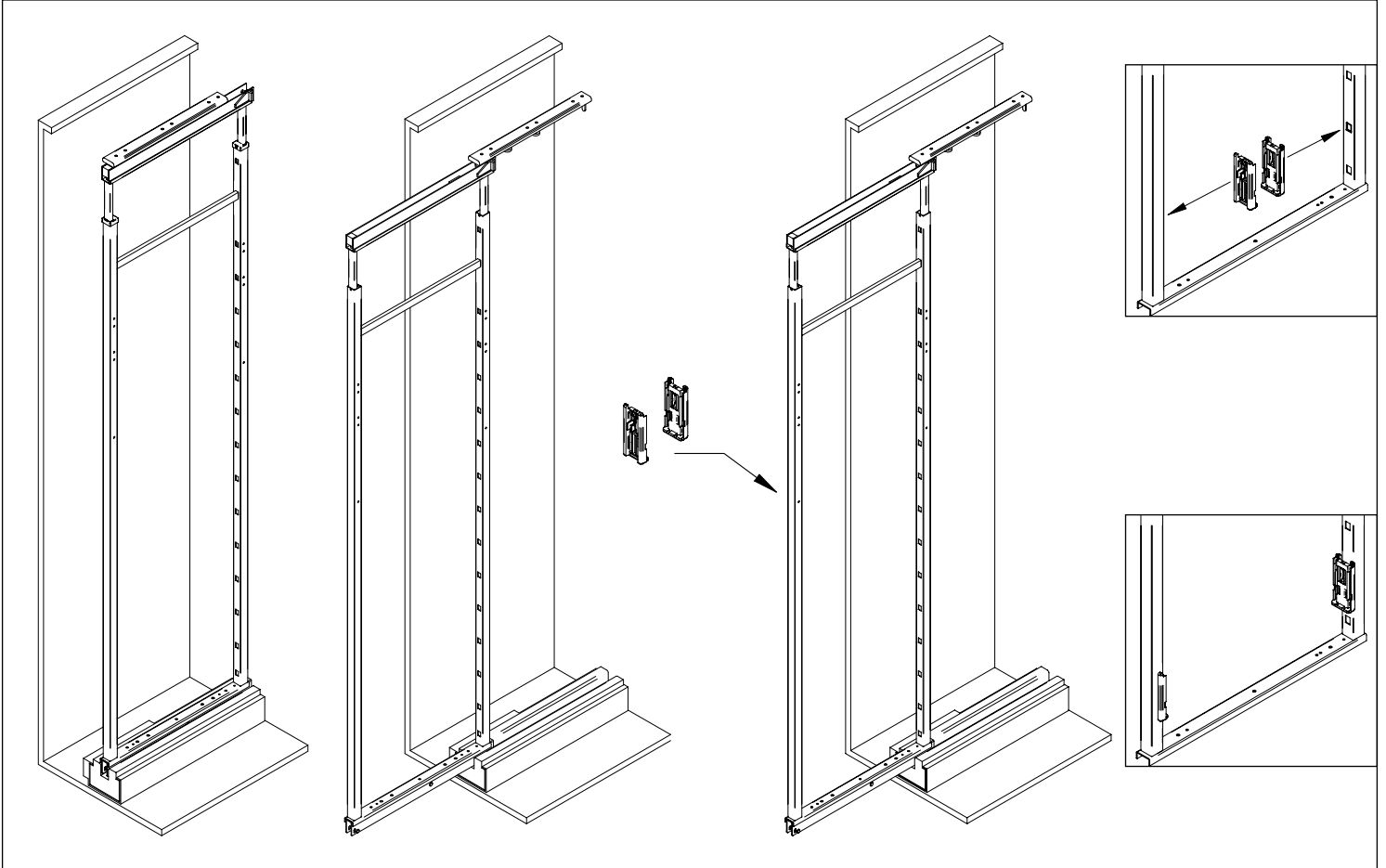

Overview and Parts Required for the Assembly of the Brackets to the Larder Unit

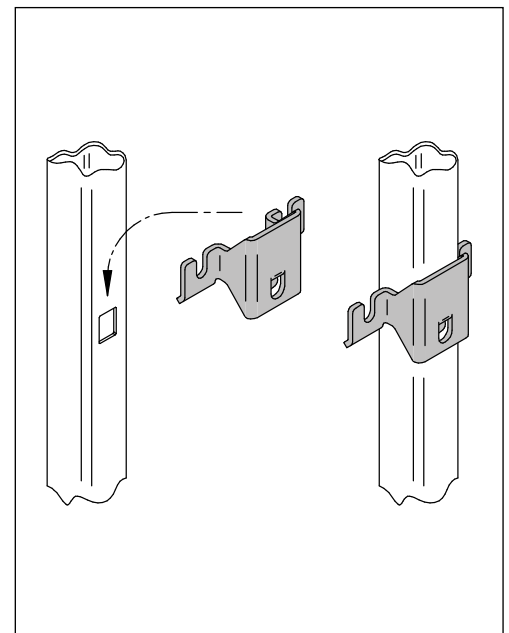
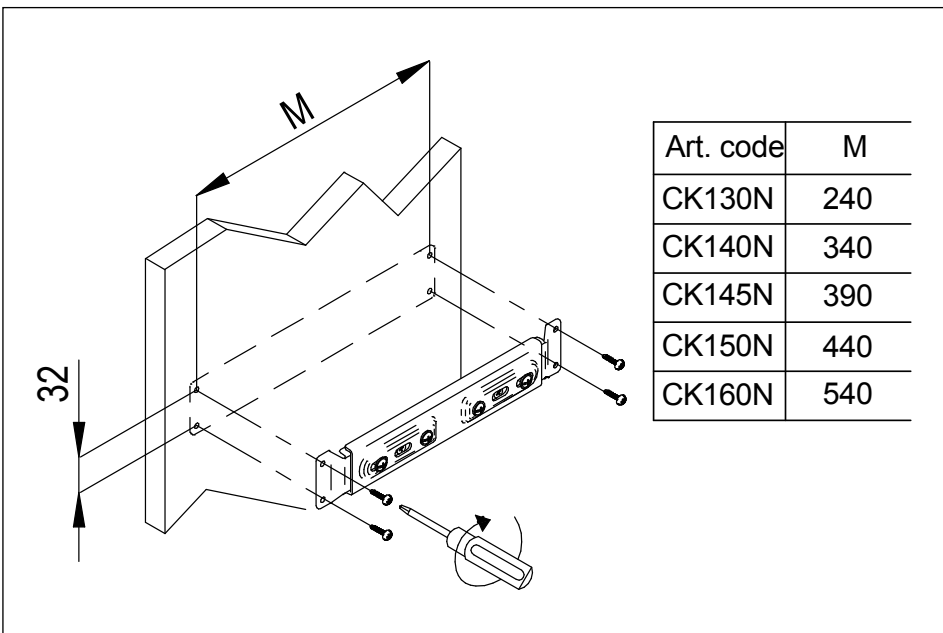
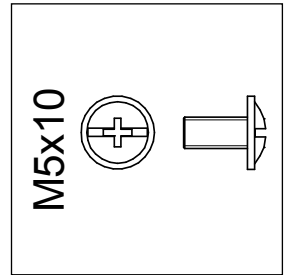
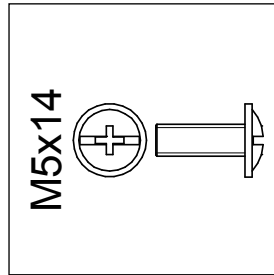
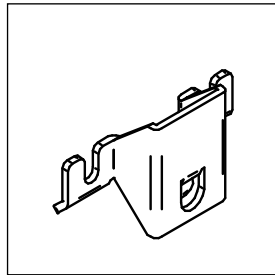
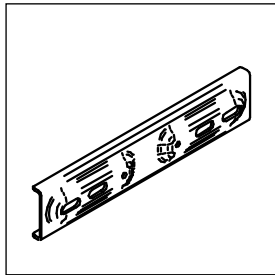
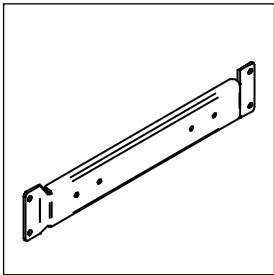
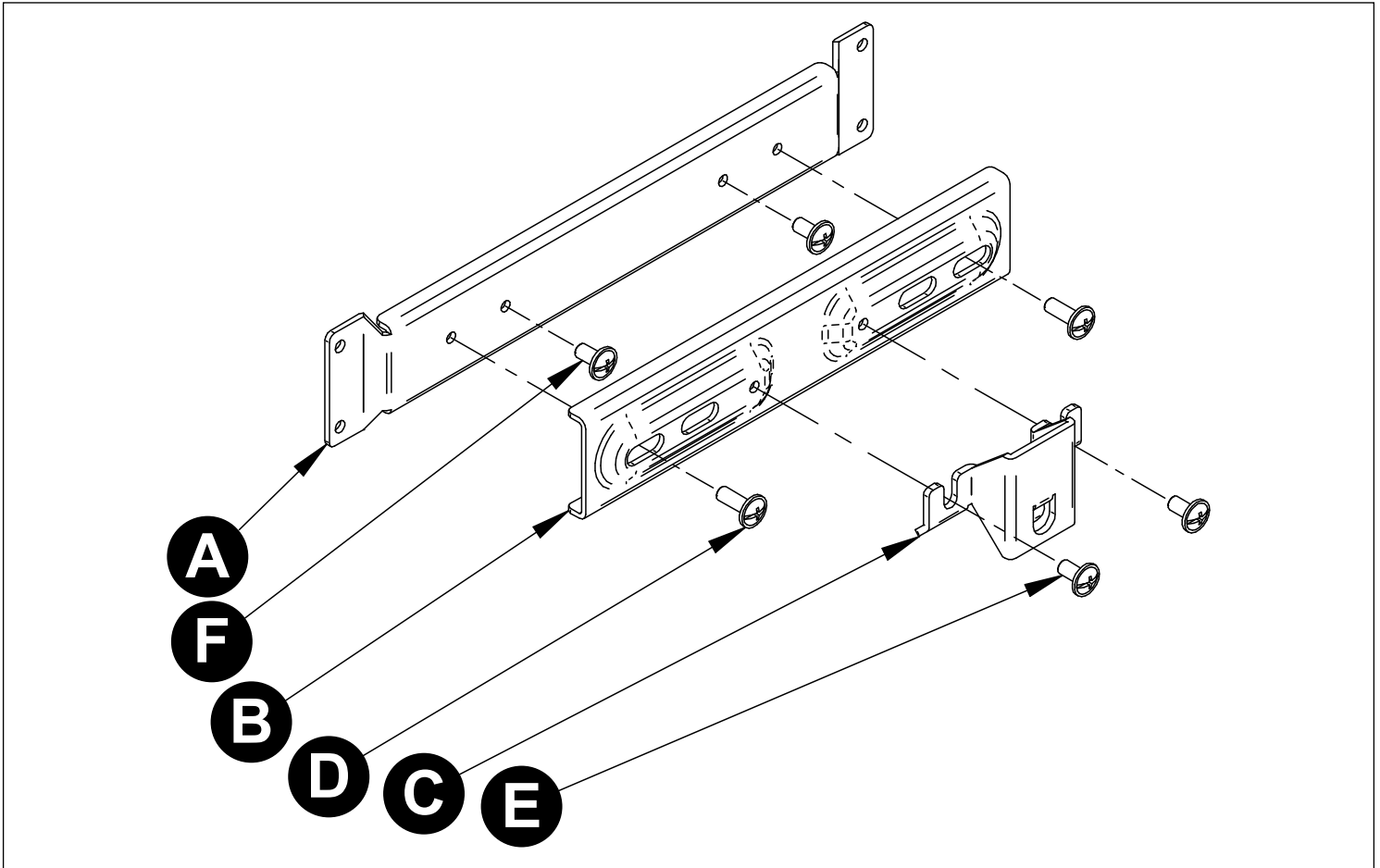

Assembly of the Brackets

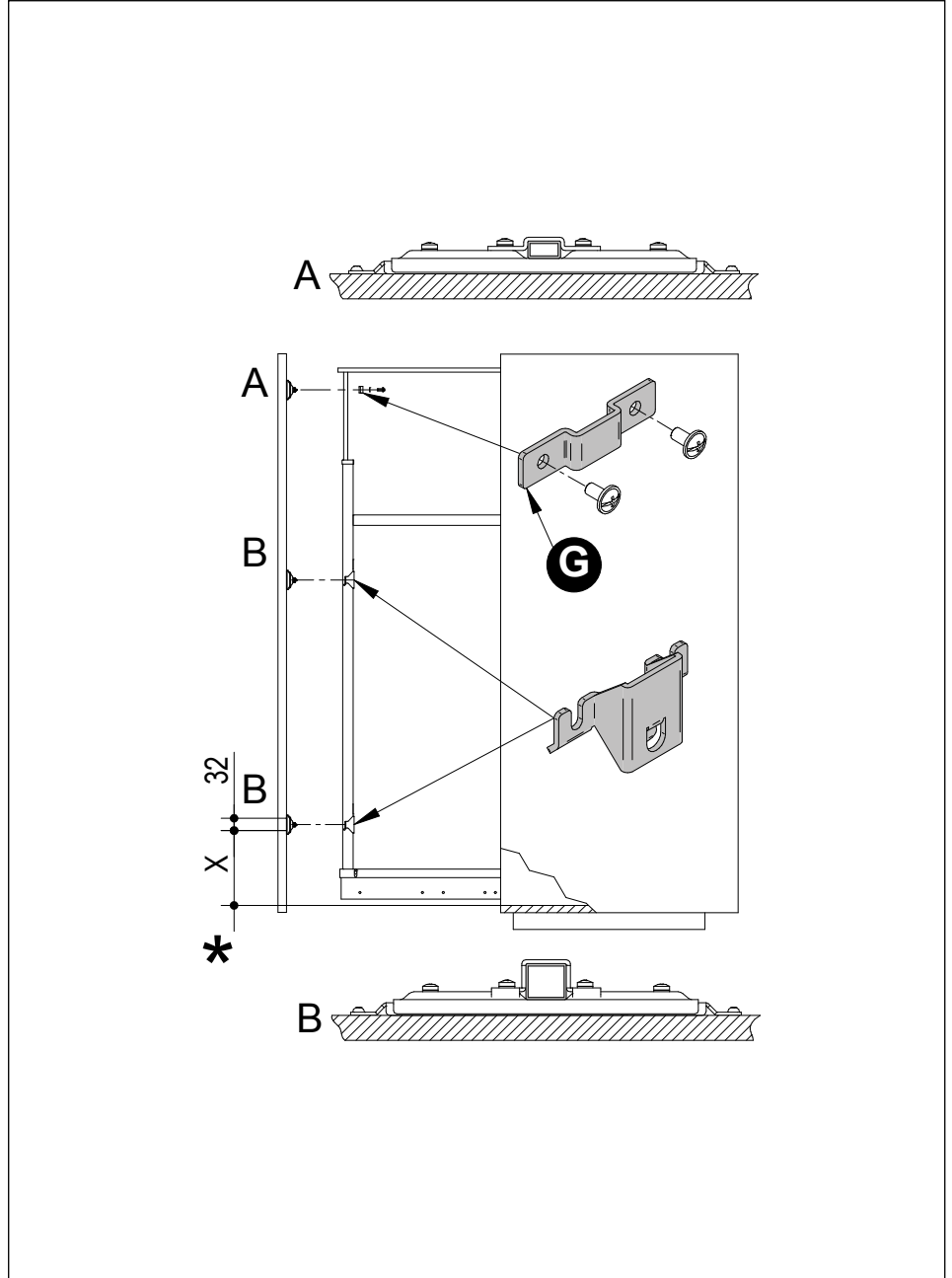
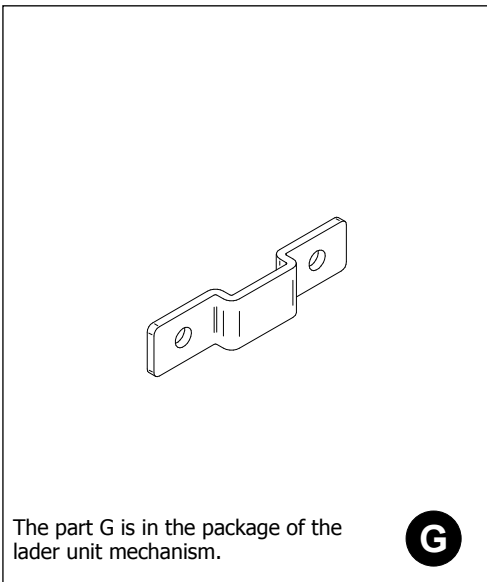
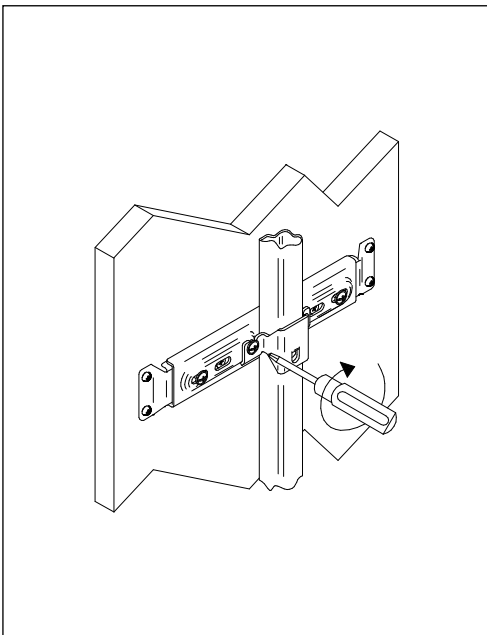
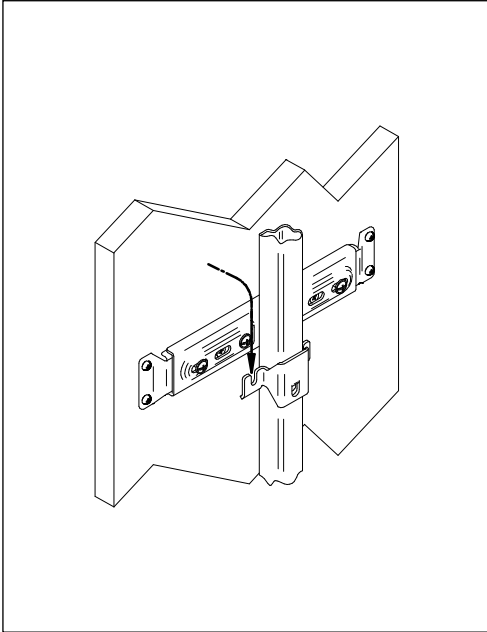

Art. code	x
GC01	102
GCSTS	102
GCFTM	102
GCFTMR	174
GCFTM200	120
GCSTM/10	115
GCTTM	113

Assembly of the Brackets

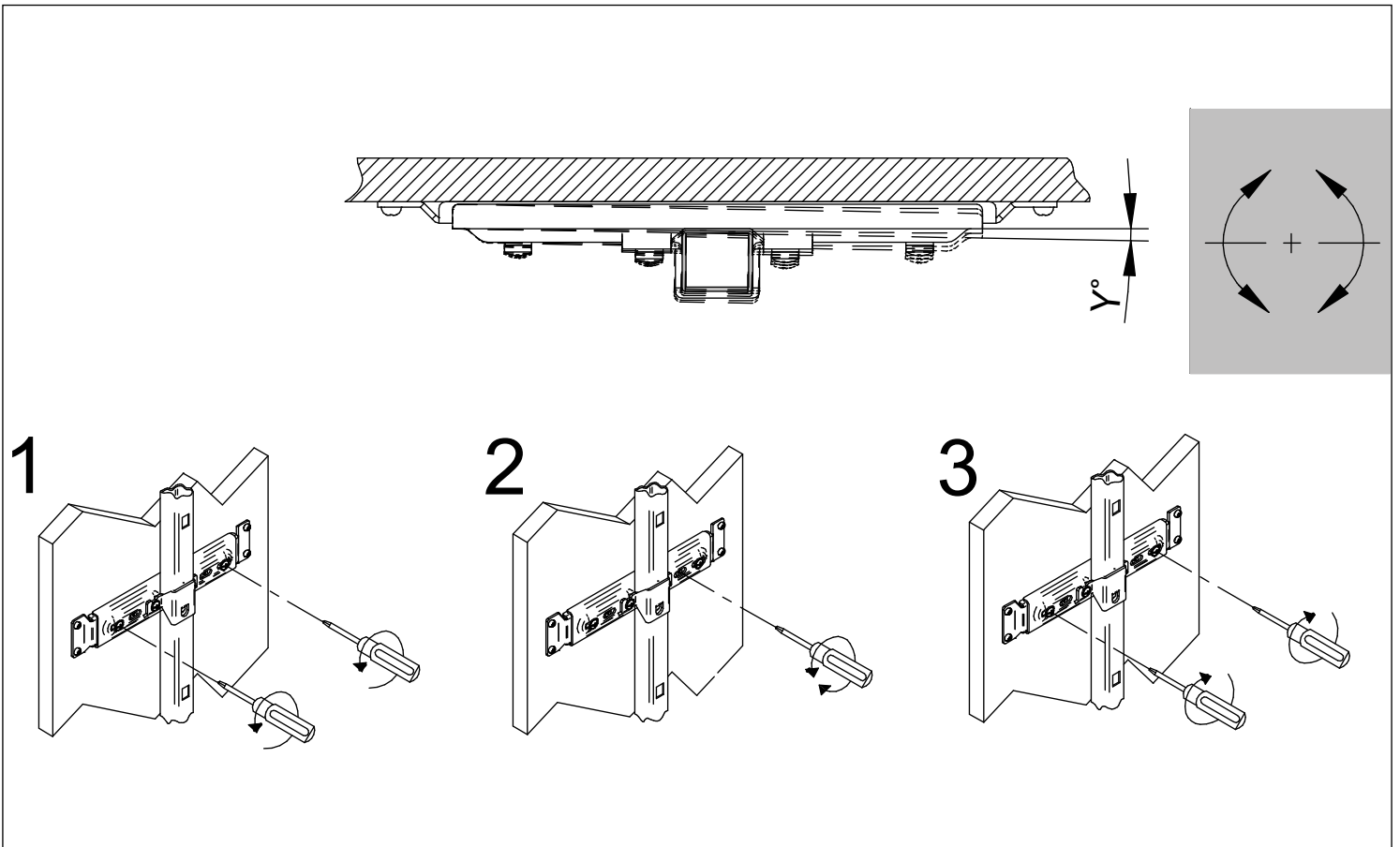
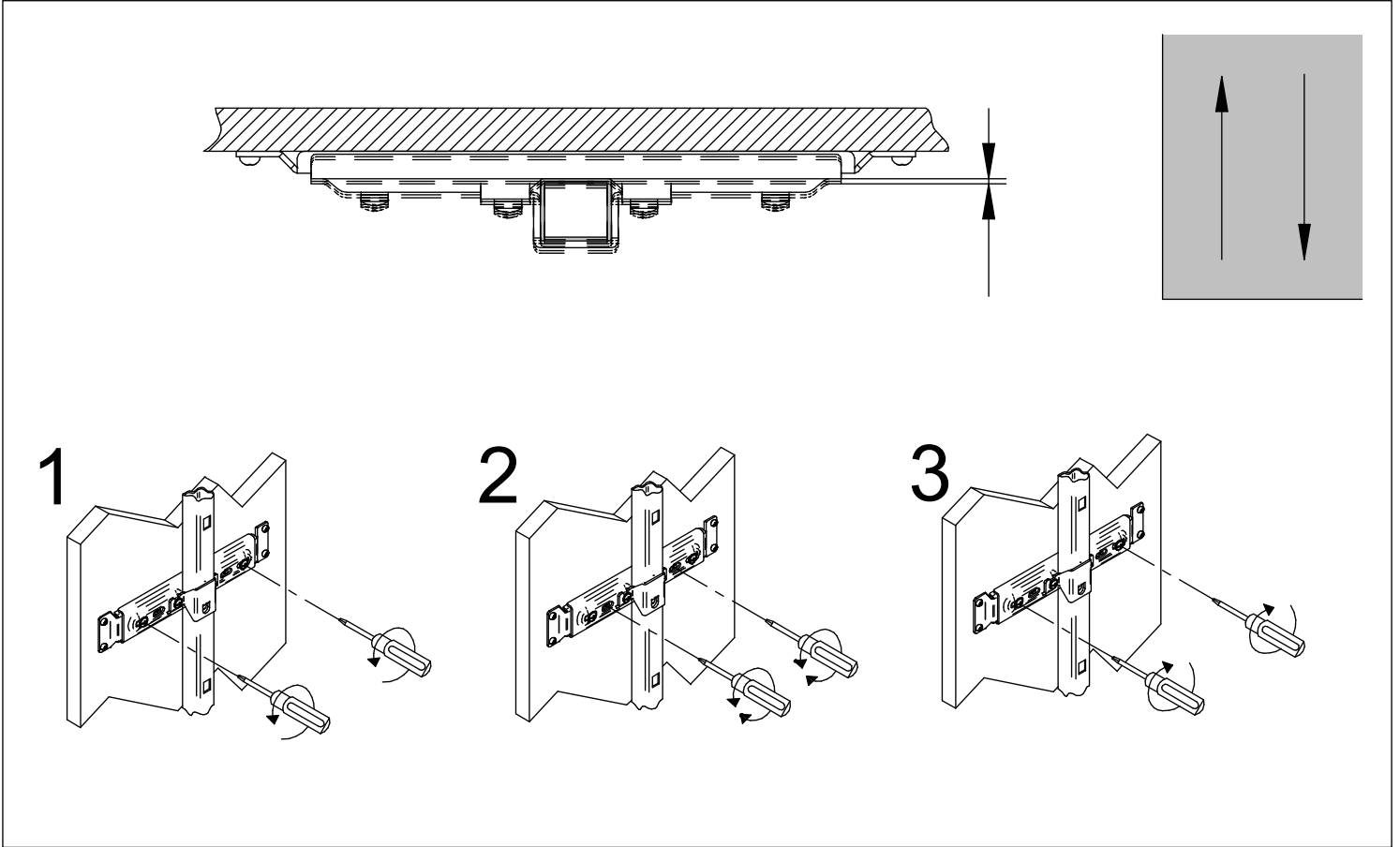

Assembly of the Brackets

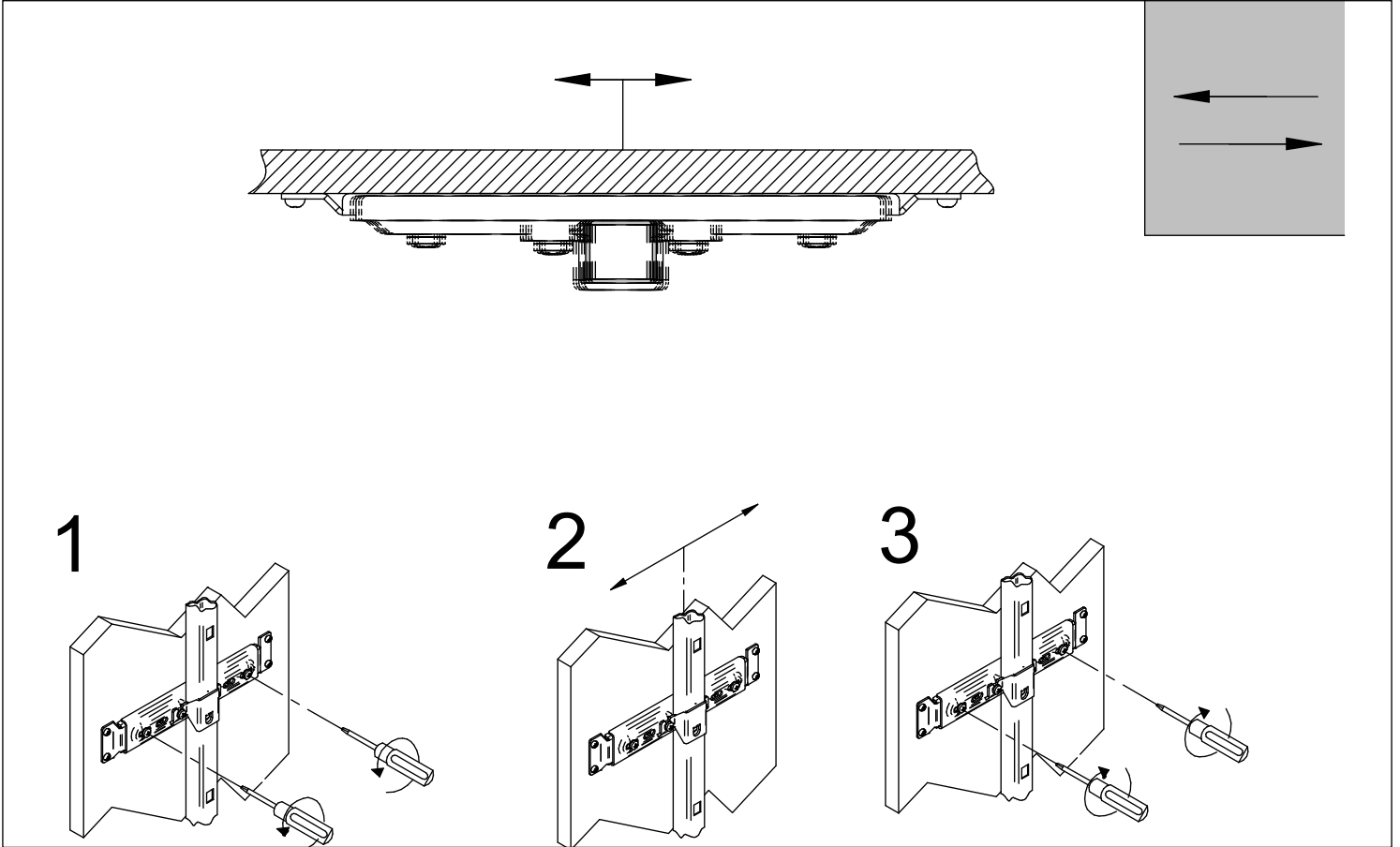



MACHINERY - MATERIALS - COMPONENTS - ADHESIVES - FOILS - PANELS - DOORS

NEY Ltd (Head Office)

Stonebridge Trading Estate
Sibree Road
Coventry
CV3 4FD

t 024 7630 8100
f 024 7630 8101
e sales@ney.co.uk

NEY Ireland

Unit 22 Blaris Ind Estate
Altona Road
Lisburn
BT27 5QB

t 028 92 673 000
f 028 92 672 999
e ireland@ney.co.uk

NEY Scotland

Block 2 Units 1-2-3
Bandeath Ind Est
Throsk, Stirling
FK7 7NP

t 01786 814 814
f 01786 814 812
e scotland@ney.co.uk